

HORIZON

TUNG
STÈNE

FABRIQUÉ
AU QUÉBEC

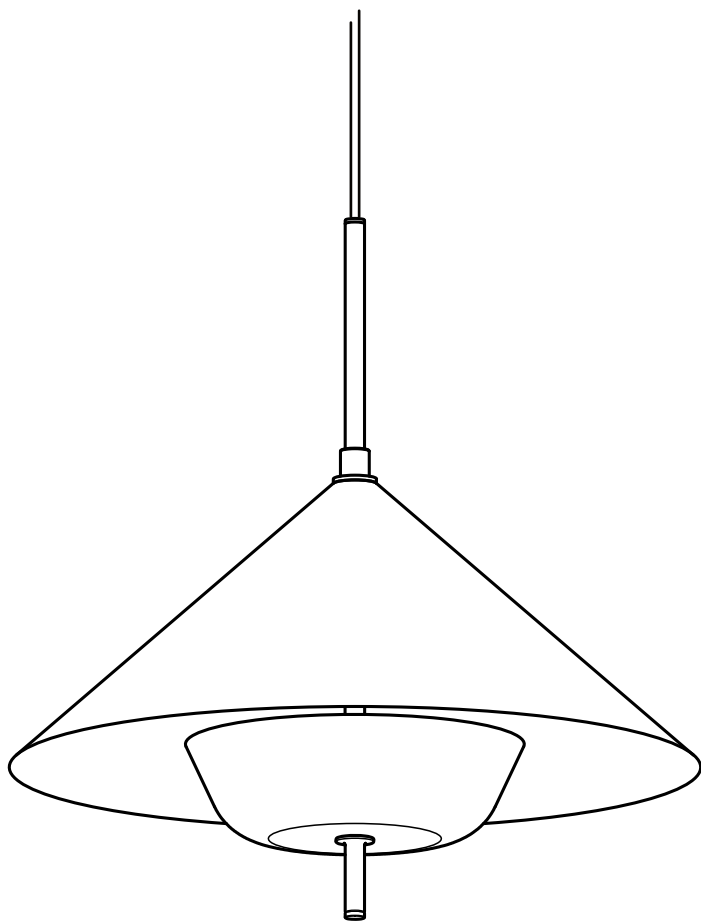

ATTENTION

Couper l'alimentation à partir du disjoncteur et s'assurer que le courant est interrompu avant de commencer. Il est recommandé de faire appel à un électricien certifié pour l'installation.

CAUTION

Turn off power at the circuit breaker and make sure that there is no power before starting. Hiring a certified electrician is recommended for the installation.

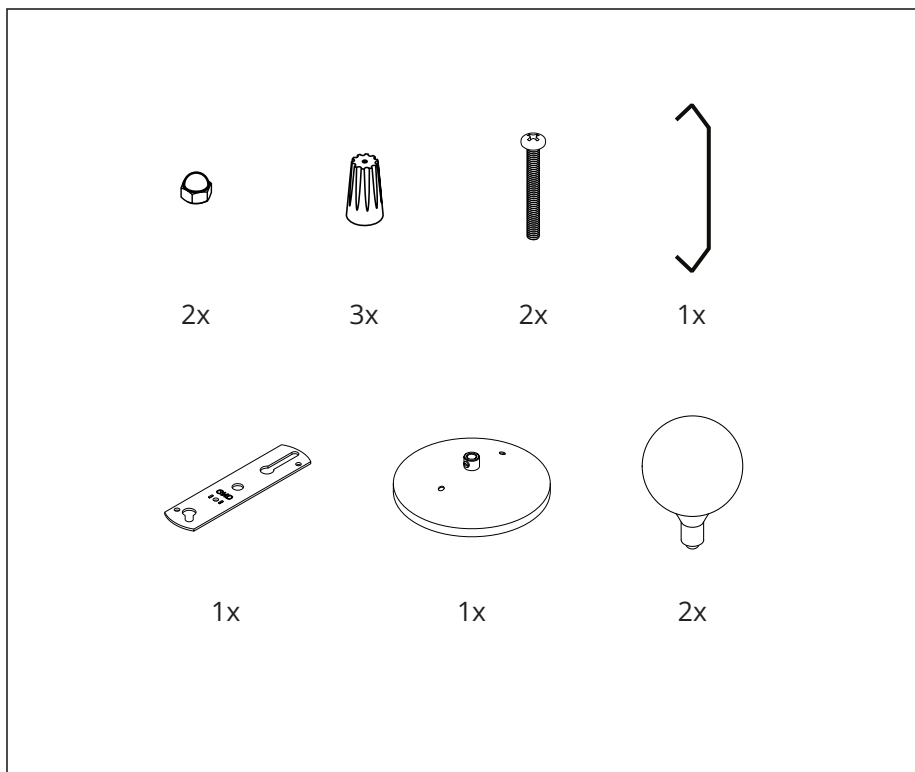

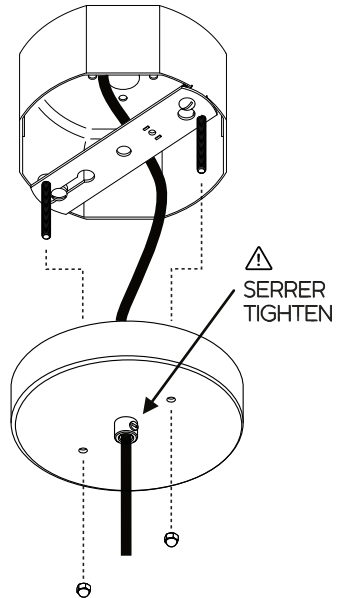
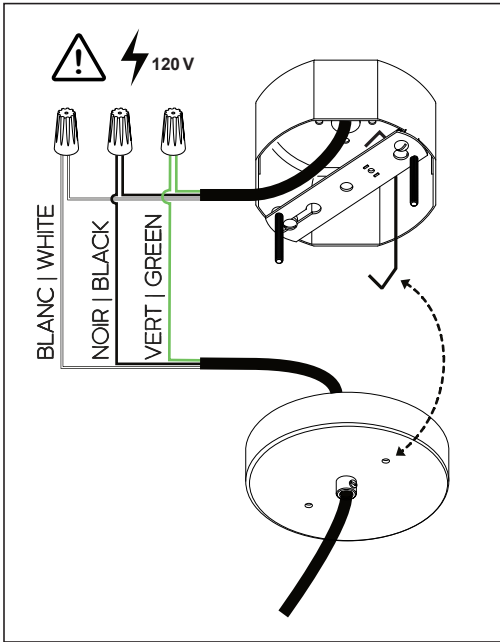
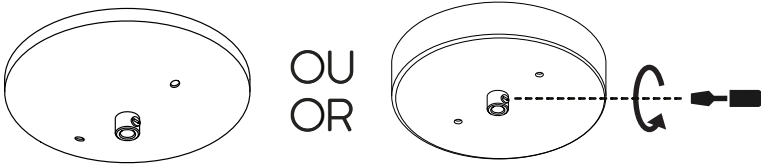
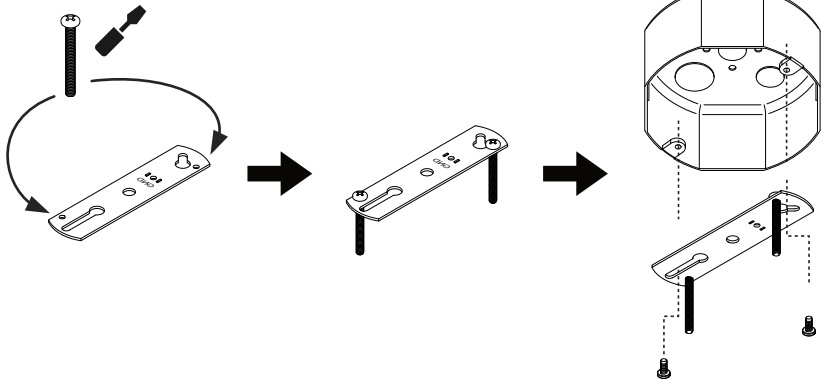

CHANGEMENT DES AMPOULES | LIGHTBULB CHANGE

